

# DESIGN NOTES

## Using the LTC6900 Low Power SOT-23 Oscillator as a VCO

Design Note 293

Nello Sevastopoulos

### Introduction

The LTC6900 is a precision low power oscillator that is extremely easy to use and occupies very little PC board space. It is a lower power version of the LTC1799.

The output frequency,  $f_{OSC}$ , of the LTC6900 can range from 1kHz to 20MHz—programmed via an external resistor,  $R_{SET}$ , and a 3-state frequency divider pin, as shown in Figure 1.

$$f_{OSC} = \frac{10\text{MHz}}{N} \cdot \frac{20\text{k}\Omega}{R_{SET}} \quad N = 1, 10, 100 \quad (1)$$

A proprietary feedback loop linearizes the relationship between  $R_{SET}$  and the output frequency so the frequency accuracy is already included in the expression above. Unlike other discrete RC oscillators, the LTC6900 does not need correction tables to adjust the formula for determining the output frequency.

Figure 2 shows a simplified block diagram of the LTC6900. The LTC6900 master oscillator is controlled by the ratio of the voltage between  $V^+$  and the SET pin and the current,  $I_{RES}$ , entering the SET pin. As long as  $I_{RES}$  is precisely the current through resistor  $R_{SET}$ , the ratio of  $(V^+ - V_{SET})/I_{RES}$  equals  $R_{SET}$  and the frequency of the LTC6900 depends solely on the value of  $R_{SET}$ . This technique ensures accuracy, typically  $\pm 0.5\%$  at ambient temperature.

As shown in Figure 2, the voltage of the SET pin is

controlled by an internal bias, and by the gate to source voltage of a PMOS transistor. The voltage of the SET pin ( $V_{SET}$ ) is typically 1.1V below  $V^+$ .

### Programming the Output Frequency

The output frequency of the LTC6900 can be programmed by altering the value of  $R_{SET}$  as shown in Figure 1 and the accuracy of the oscillator will be as specified. The frequency can also be programmed by steering current in or out of the SET pin, as conceptually shown in Figure 3. This technique can degrade accuracy as the ratio of  $(V^+ - V_{SET})/I_{RES}$  is no longer uniquely dependent on the value of  $R_{SET}$ , as shown in Figure 2. This loss of accuracy will become noticeable when the magnitude of  $I_{PROG}$  is comparable to  $I_{RES}$ . The frequency variation of the LTC6900 is still monotonic.

Figure 4 shows how to implement the concept shown in Figure 3 by connecting a second resistor,  $R_{IN}$ , between the SET pin and a ground referenced voltage source  $V_{IN}$ .

For a given power supply voltage in Figure 4, the output frequency of the LTC6900 is a function of  $V_{IN}$ ,  $R_{IN}$ ,  $R_{SET}$ , and  $(V^+ - V_{SET}) = V_{RES}$ :

$$f_{OSC} = \frac{10\text{MHz}}{N} \cdot \frac{20\text{k}\Omega}{R_{SET} // R_{IN}} \cdot \left( 1 + \frac{V_{IN} - V^+}{V_{RES}} \cdot \frac{1}{1 + R_{IN} / R_{SET}} \right) \quad (2)$$

LTC and LT are registered trademarks of Linear Technology Corporation.

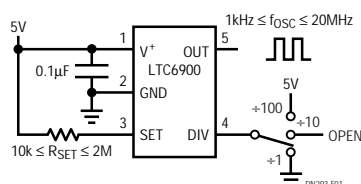

Figure 1. Basic Connection Diagram

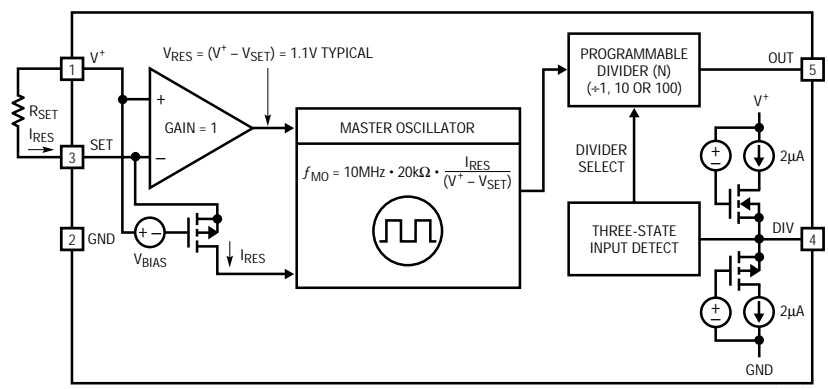

Figure 2. Simplified Block Diagram

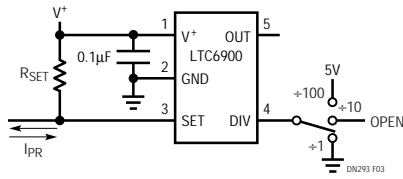

Figure 3. Concept for Programming via Current Steering

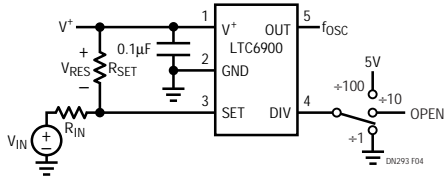

Figure 4. Implementation of the Concept Shown in Figure 3

When  $V_{IN} = V^+$  the output frequency of the LTC6900 assumes the highest value and it is set by the parallel combination of  $R_{IN}$  and  $R_{SET}$ . Also note, the output frequency,  $f_{OSC}$ , is independent of the value of  $V_{RES} = (V^+ - V_{SET})$  so, the accuracy of  $f_{OSC}$  is within the data sheet limits.

When  $V_{IN}$  is less than  $V^+$ , and especially when  $V_{IN}$  approaches the ground potential, the oscillator frequency,  $f_{OSC}$ , assumes its lowest value and its accuracy is affected by the change of  $V_{RES} = (V^+ - V_{SET})$ . At 25°C  $V_{RES}$  varies by  $\pm 8\%$ , assuming the variation of  $V^+$  is  $\pm 5\%$ . The temperature coefficient of  $V_{RES}$  is 0.02%/°C. Note that if  $V_{IN}$  is the output of a DAC referenced to  $V^+$ , the  $V_{RES}$  sensitivity to the power supply is eliminated.

By manipulating the algebraic relation for  $f_{OSC}$  above, a simple algorithm can be derived to set the values of external resistors  $R_{SET}$  and  $R_{IN}$ , as shown in Figure 4:

1. Choose the desired value of the maximum oscillator frequency,  $f_{OSC(MAX)}$ , occurring at maximum input voltage  $V_{IN(MAX)} \leq V^+$ .
2. Set the desired value of the minimum oscillator frequency,  $f_{OSC(MIN)}$ , occurring at minimum input voltage  $V_{IN(MIN)} \geq 0$ .
3. Choose  $V_{RES} = 1.1V$  and calculate the ratio of  $R_{IN}/R_{SET}$  from the following:

$$\frac{R_{IN}}{R_{SET}} = \frac{(V_{IN(MAX)} - V^+) - \left(\frac{f_{OSC(MAX)}}{f_{OSC(MIN)}}\right) \cdot (V_{IN(MIN)} - V^+)}{V_{RES} \left(\frac{f_{OSC(MAX)}}{f_{OSC(MIN)}} - 1\right)} - 1 \quad (3)$$

Data Sheet Download

<http://www.linear.com/go/dnLTC6900>

Once  $R_{IN}/R_{SET}$  is known, calculate  $R_{SET}$  from:

$$R_{SET} = \frac{10\text{MHz}}{N} \cdot \frac{20\text{k}\Omega}{f_{OSC(MAX)}} \left[ \frac{(V_{IN(MAX)} - V^+) + V_{RES} \left(1 + \frac{R_{IN}}{R_{SET}}\right)}{V_{RES} \left(\frac{R_{IN}}{R_{SET}}\right)} \right] \quad (4)$$

Example 1: In this example, the oscillator output frequency has small excursions. This is useful where the frequency of a system should be tuned around some nominal value.

Let  $V^+ = 3V$ ,  $f_{OSC(MAX)} = 2\text{MHz}$  for  $V_{IN(MAX)} = 3V$  and  $f_{OSC(MIN)} = 1.5\text{MHz}$  for  $V_{IN} = 0V$ . Solve for  $R_{IN}/R_{SET}$  by equation (3), yielding  $R_{IN}/R_{SET} = 9.9/1$ .  $R_{SET} = 110.1\text{k}\Omega$  by equation (4).  $R_{IN} = 9.9R_{SET} = 1.089\text{M}\Omega$ . For standard resistor values, use  $R_{SET} = 110\text{k}\Omega$  (1%) and  $R_{IN} = 1.1\text{M}\Omega$  (1%). Figure 5 shows the measured  $f_{OSC}$  vs  $V_{IN}$ . The 1.5MHz to 2MHz frequency excursion is quite limited, so the curve  $f_{OSC}$  vs  $V_{IN}$  is linear.

Example 2: Vary the oscillator frequency by one octave per volt. Assume  $f_{OSC(MIN)} = 1\text{MHz}$  and  $f_{OSC(MAX)} = 2\text{MHz}$ , when the input voltage varies by 1V. The minimum input voltage is half supply, that is  $V_{IN(MIN)} = 1.5V$ ,  $V_{IN(MAX)} = 2.5V$  and  $V^+ = 3V$ .

Equation (3) yields  $R_{IN}/R_{SET} = 1.273$  and equation (4) yields  $R_{SET} = 142.8\text{k}\Omega$ .  $R_{IN} = 1.273R_{SET} = 181.8\text{k}\Omega$ . For standard resistor values, use  $R_{SET} = 143\text{k}\Omega$  (1%) and  $R_{IN} = 182\text{k}\Omega$  (1%).

Figure 6 shows the measured  $f_{OSC}$  vs  $V_{IN}$ . For  $V_{IN}$  higher than 1.5V the VCO is quite linear; nonlinearities occur when  $V_{IN}$  becomes smaller than 1V, although the VCO remains monotonic.

The VCO modulation bandwidth is 25kHz that is, the LTC6900 will respond to changes in the frequency programming voltage,  $V_{IN}$ , ranging from DC to 25kHz.

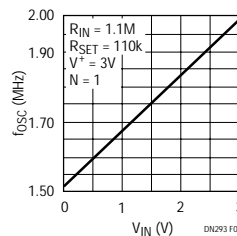

Figure 5. Output Frequency vs Input Voltage

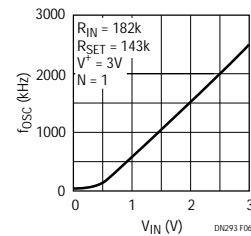

Figure 6. Output Frequency vs Input Voltage

For literature on our Oscillators, call 1-800-4-LINEAR. For applications help, call (408) 432-1900, Ext. 2525